



A DATABASE SUPPORTED 3D-GEOMETRIC MODEL FOR COMPUTER BASED ASSESSMENT AND VOLUMETRIC CALCULATIONS OF HARD COAL DEPOSITS IN THE DONETS BASIN; RESULTS OF A JOINT UKRAINIAN–GERMAN PROJECT

D. JUCH¹, A. THOMSEN², O. SPIRINA³, I. KARLASHENKO³, T. PISKOVAYA³, R. RYABCEV³

Abstract. In an attempt to make use of scientific potential for geological evaluation like resource management, a joint German–Ukrainian project was carried out during the last four years. The aim of this project was the introduction and application in the Donets Basin of a computer based coal resources assessment method originally developed for the assessment of the German hard coal deposits and was called KVB-model. The combination and adaptation of the old conception of the KVB-model with modern graphic allows for the combination of the 3D structure plans of the seams with different attributes like seam and coal property data (thickness, ash, sulphur, metamorphism, rank), state of exposure (mining zone, prospective), gas content of coal, etc. A further extension of the system may consist of the interpretation of the rocks in addition to the seams already represented in the stratigraphic profile. This would allow the application be used for stratified geological units of any kind.

Key words: coal deposits, database, computer 3D-modelling, Donets Basin.

INTRODUCTION

In spite of the general decline of hard coal mining in Europe, there still exists a large amount of geological knowledge and methodical experience referring to the European coal deposits. In an attempt to make use of this scientific potential for geological evaluations like resource management, a joint German–Ukrainian project was carried out during the last 4 years, supported by the German Ministry of Research (BMBF). The aim of this project was the introduction and application in the Donetsk Basin of a computer based coal resources assessment method originally developed for the assessment of the German hard coal deposits (Juch *et al.*, 1994). The 3D-modelling of complex geological structures is still a rather laborious task, because of the large number of different basic information and the often complicated geometry that are characteristic for geological bodies. Therefore, systems for 3D-modelling of geological bodies often make use of high speed and large memory computers combined with enhanced graphic capabilities, and require a considerable amount of interactive work.

The present paper proposes a different approach how, for the purpose of the assessment of hard coal deposits, the geometry of stratified geological bodies delimited by tectonic elements may be modelled with reduced working expenditure.

With some compromises concerning the detail of the 3D model, we use standard PC hardware equipment, standard database and graphic software, and a proprietary program for geometric construction. The concept of this so-called KVB-model was originally developed at the geological survey of North-Rhine Westphalia (Geologisches Landesamt NRW, Krefeld/Germany) for the purpose of assessment of the West German hard coal resources (Thomsen, 1984; Buettner *et al.*, 1985). Its performance and successful application led to the creation of a considerable database which permits flexible volume calculations differentiated according to user-defined limiting criteria and reserves or resources classes (Juch, 1996; Daul, Juch, 1999). Besides the calculation of coal volume, the method supports the automatic construction of approximate 3D-models of a large number of seams.

Similarities between the Ukrainian and German deposits suggested trying the same method in the Donets Basin. The conversion of the method to the possibilities of modern PC equipment required a thorough revision of the concept, which was done in Germany, and the complete rewriting of the software which was done by the Ukrainian partners, both partners working in close contact. Moreover, a new methodical approach has

¹ Geologischer Dienst Nordrhein-Westfalen, Krefeld, Germany

² Geologisches Institut Universitaet Bonn, Germany

³ STG "Cooperation" of Donetsk SRGE, Artyomovsk, Ukraine

been developed and applied by the Ukrainian working group. The possibilities of the new KVB-model indicate several new applications of this comparably easy way of transforming con-

ventional geological information into a 3D model. The project was finished at the end of October 2000 — in the present paper we present a first summary of the results.

MAIN PRINCIPLES OF THE KVB-MODEL ASSESSMENT SYSTEM

When calculating and evaluating resources, several problems are to be solved, e.g.:

— how to ensure comparable figures when limiting criteria differs from one deposit to another and change through time?

— how to compare global resource figures based on percentages of coal content in large rock formations with the detailed assessments of individual seams, as usually applied by mines?

The KVB-model solves both problems by considering each seam, or rather parts of a seam, in a deposit individually. An approximate polygonal representation of the geometry, together with other respective geological information, is stored in a relational database. Thus calculations of classes of resources or reserves are supported by simple database queries, with a free choice of the cut-off values of the limiting parameters (e.g. coal thickness, depth, coal quality). As the number of such polygons is considerable, most of these geometrical elements are calculated automatically, using a simple geometrical construction model adapted to stratified and tectonically faulted geological bodies. It is based on the following assumptions:

— stratigraphic, tectonic and artificial subdivisions of a coal deposit result in the delimitation of relatively homogenous parts of each seam which are represented by simple geometric units, named “sectional coal beds” (FTF = “Floetzteilflaeche”);

— a reasonable subdivision assumed, these sectional coal beds can be approximated by planar surfaces, and laterally be delimited by polygonal borders, which consist of tectonic elements (faults or fold axis), artificial boundaries or the unconformable surface of the coal bearing unit;

— a number of sectional coal beds in a stratigraphic sequence, which are delimited by the same border elements, form a “block”; such a block with its boundaries can be roughly described as a deformed prism.

Starting from these geometrical assumptions, we proceed as follows:

— on the basis of the projection of a few selected seams, the blocks are delimited as the smallest structurally homogenous units of a deposit; each block is defined by an upper (top) and lower (bottom) seam and common delimiting elements (Fig. 1)

— the digitisation of the upper and lower seam respectively of the corresponding sectional coal beds (FTF) provides all elements that define the geometry of a block:

a) a number of depth points in the upper and lower seam serve to calculate the position and dip of an approximation plane,

b) the delimiting elements of the sectional coal beds are defined as closed polygons consisting of a numbered sequence

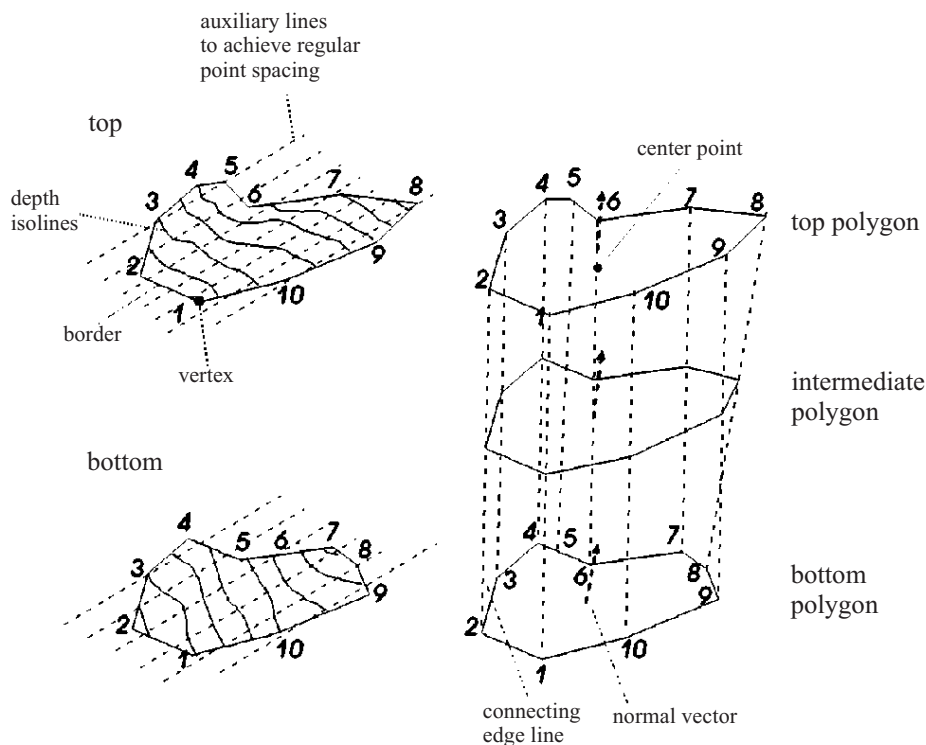

Fig. 1. Principle of block construction

of “border points”, i.e. polygon vertices; the border points in the upper and the lower seam of a block must correspond in number and sequence; straight lines connecting upper and lower border points then define the lateral boundaries of a block;

— the interior of a block, which consists of a number of intermediate sectional coal beds, is constructed as follows:

a) a representative stratigraphic column containing all intermediate seams is established for each block,

b) the approximation planes of the intermediate seams are assumed to vary proportionally with their distances from the upper and lower seam,

c) the lateral limits of all intermediate sectional coal beds are defined by the intersections of the lines connecting corresponding polygon vertices in upper and lower seam of a block with the intermediate planes.

This assessment method, called KVB-model (KVB = KohlenVorratsBerechnung /coal resources calculation), has the following characteristic features:

— the input data are based on geological interpretations; only a small portion of the seams resp. FTF needs to be digitised, either directly or by scanning and vectorisation; the remainders are constructed automatically;

— the respective size of the blocks and sectional coal beds (FTF) depends only on the tectonic structure of the deposit and the geological confidence determined mainly by the density of basic information, e.g. boreholes.

Moreover, more detailed or more generalising block subdivision may be chosen, depending on the available working expenditure. Experience from the original KVB project showed that the geometric simplifications of the model led to quite acceptable small errors of the calculated coal volume.

After the development of the KVB method (Thomsen, 1984), its application resulted in a considerable database containing 9,000 blocks and 237,000 sectional coal beds (FTF), which describe and quantify the geometry of the West German hard coal deposits (Juch *et al.*, 1994)

TRADITIONAL EVALUATIONS OF THE COAL SEAMS IN THE DONETS BASIN

There are about 315 coal layers on the territories of 30 coal bearing areas in the Carboniferous Donets Basin. The number of seams with thickness of more than 0.45 m varies from 3 in the northern part to 50 in the central area, if only seams are considered with a rather constant thickness in large territories of 50–60 km² (stable layers). Furthermore, a distinction is made between seams with less constant thickness covering territories of 20–30 km² (relatively stable) and less than 20 km² (non-stable). The usual distance between coal layers is 20–40 meters (Geologija..., 1963).

To define the areas and to calculate the prognostic resources of coals, an evaluation system had been established in former times at the Ukrainian/Russian geological organisations, which comprised special maps on a scale of 1:25,000 for each coal bearing area, 1:100,000–200,000 for each regional part (Donets, Lugansk and Rostov), and 1:500,000 for the

whole Donets basin. Its complete performance takes a cycle of 25–30 years (Spirina, 1998).

The first stage of the last 8-th integrated cycle of that work has been completed only in a few areas. Due to the present difficult economic situation, such evaluations are considered as very expensive. Therefore an optimised way of evaluation was looked for, to use the huge amount of geological information accumulated during the last 20–30 years period for the development of prognostic tasks. This led to the suggestion to use the German experience of the KVB-model. On the other hand, the German side was interested in the adaptation of the existing system to a modern computer platform. So, a joint project was established, aiming at a further development of the KVB method and at the regional assessment and evaluation in a test area — Krasnoarmeisk — of the Donets Basin.

DEVELOPMENT AND APPLICATION OF THE KVB-MODEL IN THE DONETS BASIN

The project began with gathering of geological information in the test area of ca. 1000 km². Consequently, in a first stage 6 main seams were projected on a scale of 1:25,000. Simultaneously, the rules of block subdivision as defined in the original German project were adapted and applied to the situation in the Donets Basin.

At the same time, the basic stratigraphic information was gathered from a large number of boreholes and composed to stratigraphic columns, which are representative for each block. To cope with the requirements of data processing, a hierarchical codification system for the seam stratigraphy was developed, using 6 digit numbers ascending from the base to the top. The first digit of this code defines the suite (“F” resp. c2-1 = 1,

“M” resp. c2-7 = 7), while the last digit may be used to define local developments or individual banks of one main seam.

After the acquisition of suitable hard- and soft ware, all geological information needed for the KVB-model was assessed digitally, and stored in a small number of data base tables: “Block” (the parameters of the block construction), “Profile” (the stratigraphic columns), digitised “FTF” (defining block geometry), calculated “FTF” (geometry constructed automatically), and “Results” (depth, thickness, area, coal volume) (Fig. 2).

To facilitate both the geological evaluation and data management, the test area was subdivided into several local sub-units called “megablocks” or GRS (= GRoss-Scholle). For each GRS megablock, there is a corresponding set of data base

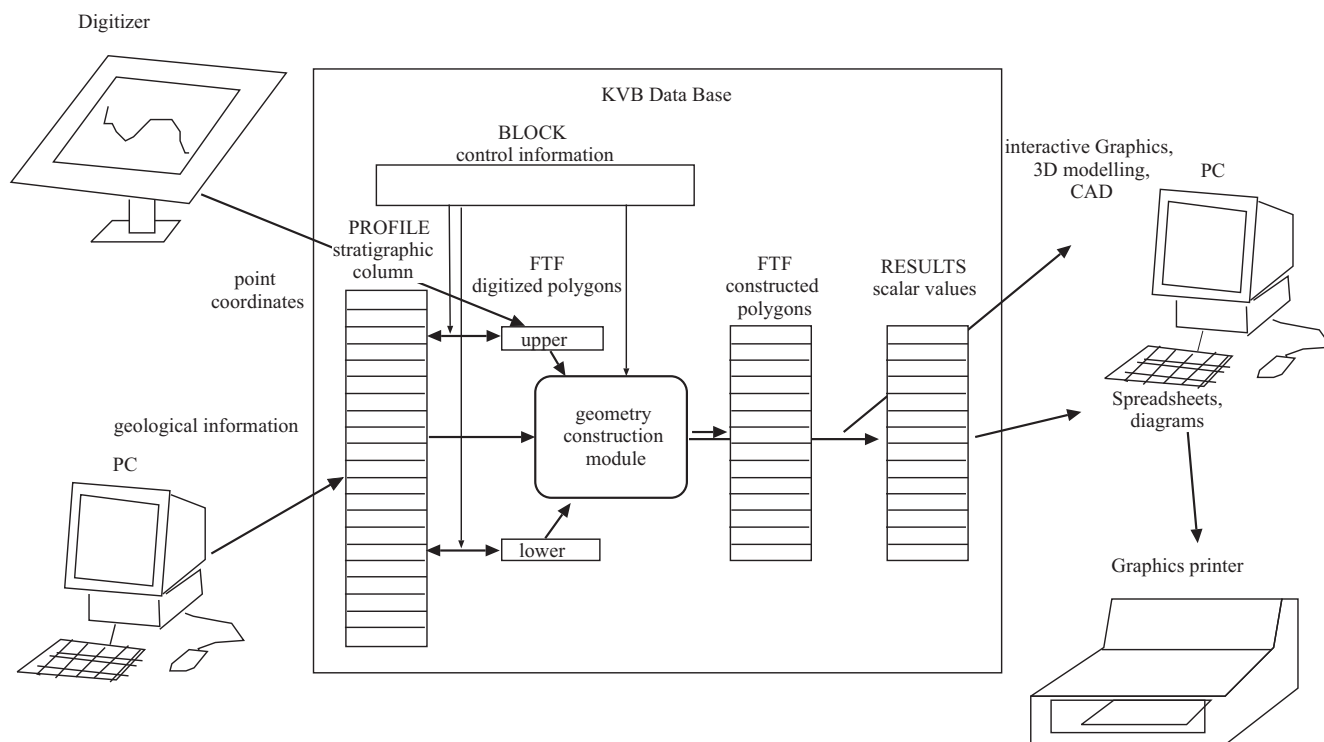

Fig. 2. The KVB system (KVB — KohlenVorratsBerechnung)

tables as described above which contain between some tens to two hundred blocks. The new program for the automatic construction was developed by R. Ryabcev following the conception described by Thomsen (in Buettner *et al.*, 1985).

Before calculating the final results, a control of the assessed and calculated data is necessary. Besides automatic and visual controls of input tables, this is particularly important for the automatic constructions of the blocks. Due to the complex spatial relations, errors of the block construction cannot be avoided completely. Therefore, each block has to be visually checked for geometrical plausibility. This can be done rather easily by means of modern interactive graphic

systems. As a result, we obtain a 3D database of each assessed megablock with all seams and sectional coal beds. From this database, coal volume and resources calculations for any definition of classes and limiting criteria are performed by simple database queries, and further processed with standard tools resulting e.g. in aggregated tables and corresponding diagrams. At the same time, 3D structure plans can be produced. Moreover, with the support of appropriate data interfaces, the approximate KVB geometry model can be used as a starting point for further interactive 3D-modelling with specialised software.

CONCLUSIONS

A new version of the KVB geometry model and database was developed that relies on common PC hard- and software. Its application was tested in a prospecting and mining area of 1,000 km² in the western Donets Basin. Starting from the projection and digitisation of 6 main seams, which contain ca. 1,100 sectional coal beds (FTF), ca. 950 blocks and ca. 12,500 sectional coal beds have been constructed automatically.

These sectional coal beds now form the database for any differentiated coal volume or reserves calculation, and 3D representation of every seam in the assessed part of the western Donets Basin. The combination and adaptation of the old conception of the KVB-model with modern graphic systems opens now new possibilities of application and further development. The system allows for the combination of the 3D structure

plans of the seams with different attributes like seam and coal property data (thickness, ash, sulphur, metamorphism, rank), state of exposure (mining zone, prospective zone), gas content of coal, etc. Facial peculiarities of seams like wash outs and split ups of separate banks may be taken into account by further subdivisions of individual sectional coal beds.

A further extension of the system may consist of the integration of the rocks in addition to the seams already represented in the stratigraphic profile. This would allow its application to stratified geological units of any kind. Moreover, to achieve an improved adaptation of the sectional coal beds to the tectonic deformation structures, the possibility of introducing curved surfaces e.g. using splines into the KVB-model may be investigated.

REFERENCES

- BUETTNER D., ENGEL H., JUCH D., ROOS W.-F., STEINBERG L., THOMSEN A., WOLFF M., 1985 — Kohlenvorratsberechnung in den Steinkohlenlagerstätten Nordrhein-Westfalens und im Saarland. BMFT-FB-T, 85-147: 208 pp. Bonn.
- DAUL J., JUCH D., 1999 — Die Verteilung der Vorräte der Steinkohlenlagerstätten an der Ruhr vor dem Abbau und zum 1. Januar 1995. *Glückauf*, **135**: 34–42.
- GEOLOGIJA mestorozhdenij uglya e goryuchih slancev SSSR. Donectkiy basseyn, 1963. V. 1, 1210 pp. [in Russian]. Gosgeoltechizdat, Moskva.
- JUCH D., 1996 — Assessment of West German hardcoal resources and its relation to coalbed methane. In: Coalbed methane and coal geology (eds. R. Gayer, I. Harris). *Geol. Soc. Spec. Publ.* **109**: 59–65.
- JUCH D., ROOS W.-F., WOLFF M., 1994 — Kohleninhaltserfassung in den westdeutschen Steinkohlenlagerstätten. *Fortschritte in der Geologie von Rheinland und Westfalen*, **38**: 189–307.
- SPIRINA O.I., 1998 — Ossobennoy kartographicheskikh issledovaniy v Donetskom basseynye [in Russian]. *Journal Mineralni resursi Ukraine*: 20–24. Kiev.
- THOMSEN A., 1984 — Digital representation of geological information and geostatistics in coal resources calculation in the F.R.G. *Sci. de la Terre, Ser. Inf.*, **21**: 79–105.